

Construction Revolution

The Implant Method revolutionizing the Global Construction Industry

Corporate Profile

 **GIKEN**

GIKEN LTD.

 **SEKO**

GIKEN SEKO CO., LTD.



Realizing Ideal Situations in Construction

Observing The Five Construction Principles

Infrastructure is a basic need for civilized societies. "The Five Construction Principles" are the universal criteria for construction method selection, by considering ideal situations for construction work under public perspective.

In any construction project, the five aspects i.e. Environmental Protection, Safety, Speed, Economy and Aesthetics, should be fulfilled in the form of equilateral pentagon.

Giken is a "New Methods Development Company", which provides original foundation structures and methods that fulfill The Five Construction Principles.



Coexistence of Environment and Civilization

Because of environmental disruptions, natural disasters and complex and aging infrastructures, the present-day society is facing more and more challenging situations.

We at Giken are creating an environmentally friendly sustainable society by providing infrastructures for safety and prosperity based on the advantages of the Press-in Method.



Guard Lives, Culture, History and Properties from Disasters

Disaster Prevention

Advantages
of
Press-in Method

Infrastructure Reformation

Minimizing Environmental Impact and Improving Society Standards

Press-in Principle

The Silent Piler grips previously installed piles and presses next pile into the ground with static load, by leveraging reaction force (extraction resistance force) of reaction piles.

The Press-in Principle enables our compact machine (Silent Piler) to generate a large force by obtaining leverage from the Earth.

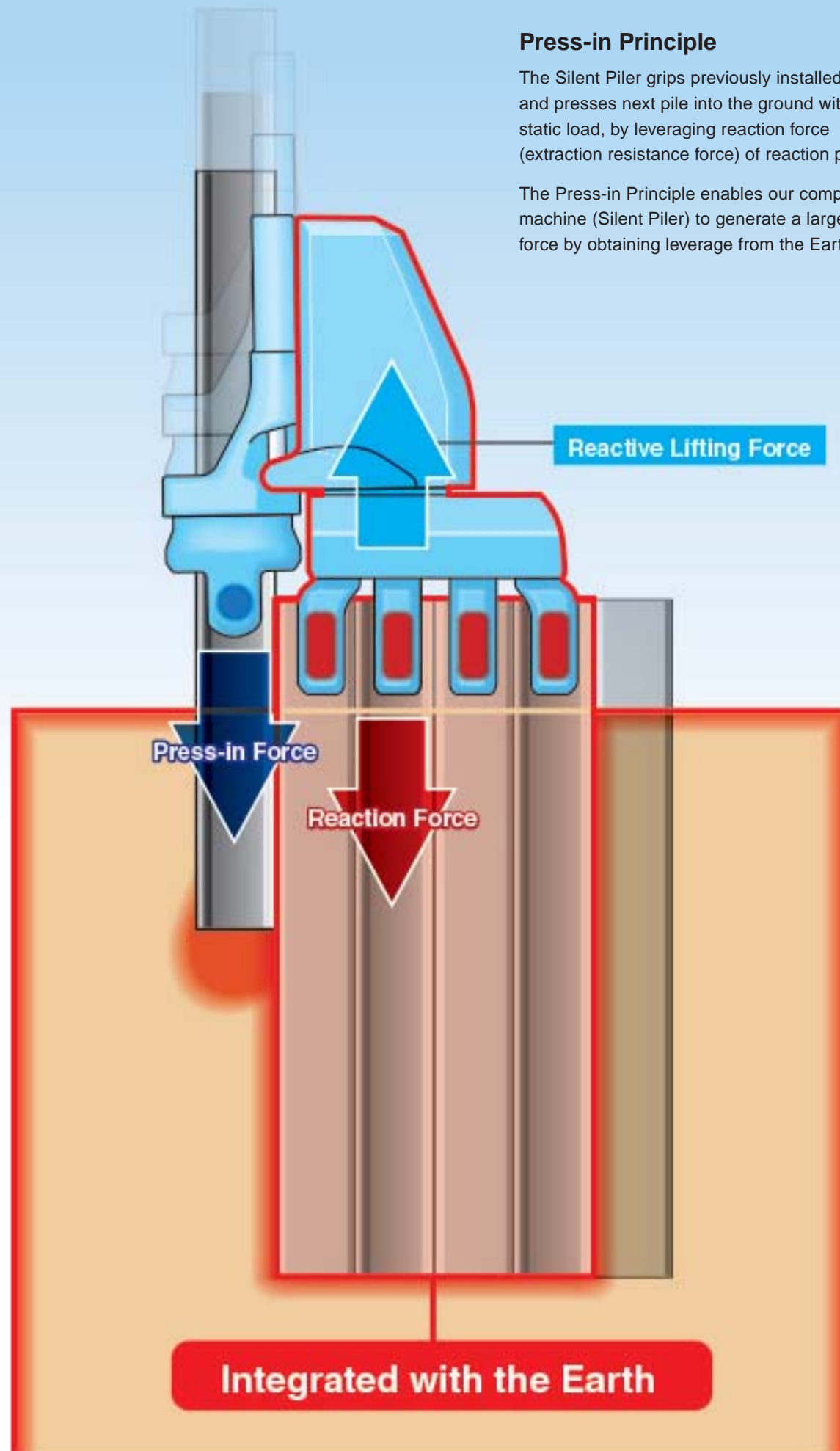

Historical Innovation of Foundation Work using the Press-in Principle

Giken turned the "Press-in Principle" to practical use and eliminated construction pollution caused by pile driving

Giken Group was established in 1967 as a company to solve construction pollution.

Giken developed the Silent Piler in 1975, which was the first ever realized practical product of the Press-in Principle virtually eliminating noise and vibration.

Since then, Giken has consistently been developing machines and methods based on the advantages of the Press-in Method.

SILENT PILER™

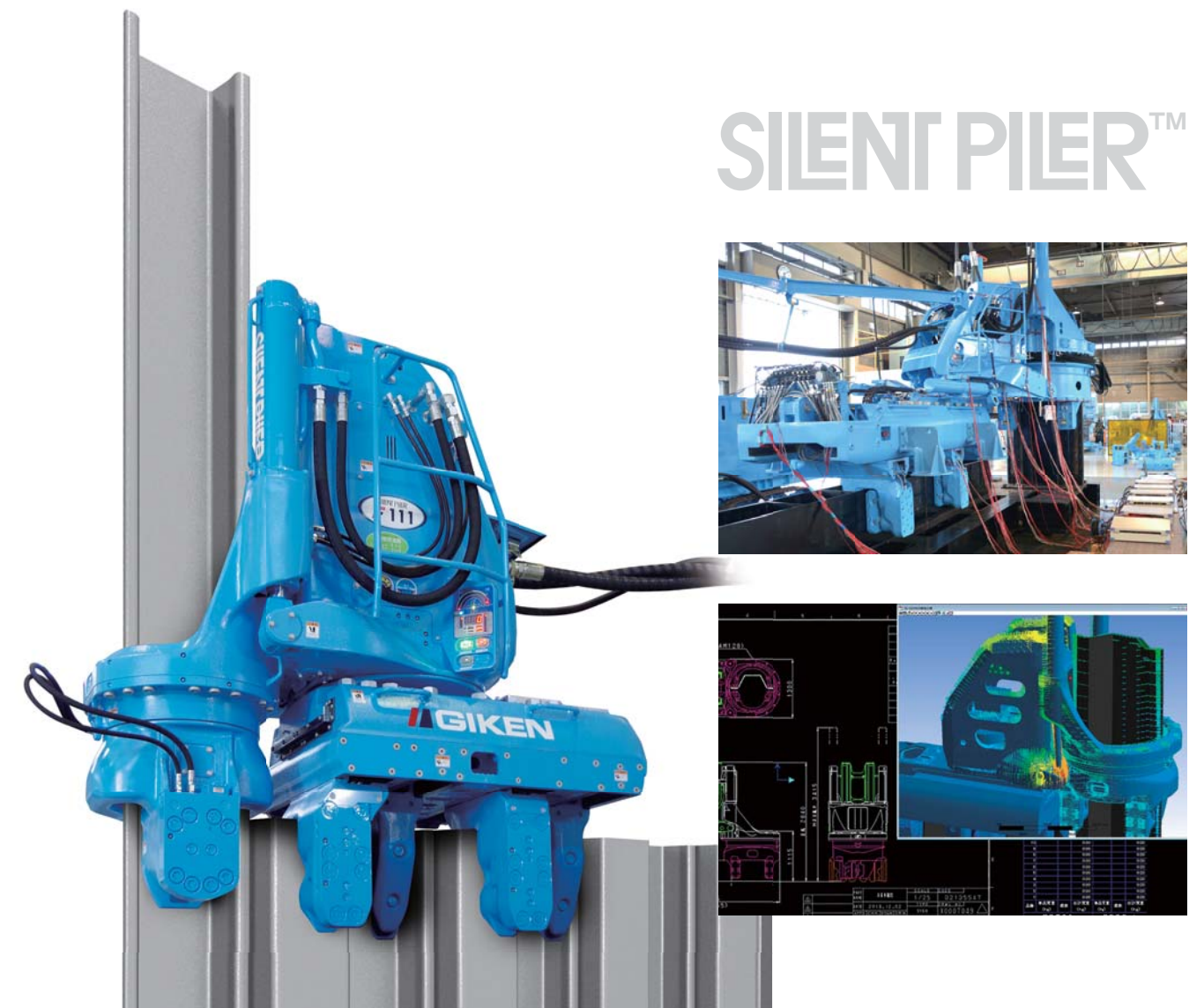

GRB System

The GRB system applies the Press-in Principle which states that a reaction force is obtained from completed piles. In this way, all of the steps of the process, from transporting and pitching the pile, to pressing it in, can be carried out from a position on top of the existing piles.

Because all of the equipment is self-supporting and grips onto the completed piles, there is no risk of overturning, and the area affected by the works is reduced to the width of the machinery on the piles.



Achieves "Minimum Temporary-Work Method" by Internal Innovative Creativity

Make the Impossible Possible by Overcoming Various Site Restrictions on Construction Works

The advantages of the Press-in Method are that it is not only virtually noise and vibration free, but it also has an epoch-making "Minimum Temporary-Work" aspect, which was realized by internal company innovations.

Therefore, even over water, on sloping or uneven ground, in narrow spaces, or locations with restricted headroom, the GRB system has essentially no need for any temporary structures, like platforms or access roads, and can focus efficiently on the purpose of the project, "building the desired infrastructure".

Also, difficult ground conditions, such as cobble or boulder mixed soil and rock, was overcome by our original innovative creativity, and expanded the applicability of the Press in Method dramatically.



Overhead Clearance Method



Rail Safe Method (Zero Clearance Method)



Gyopress Method

Tubular piles with relevant bit configurations are installed by the "rotary jack-in" system without affecting the environment or surroundings. Therefore, it meets the higher demand to renew and strengthen infrastructures in a socially conscious way.

Structural Revolution of Disaster Prevention Infrastructure using Implant Structure

The Press-in Principle allows consolidation with the Earth, forming resilient structure

Implant Structure that is securely consolidated with the Earth is highly resistant to ground displacement caused by the motion of earthquakes, tsunami, and other external forces, thus, serving as a "resilient" disaster-prevention infrastructure.

Implant Structure

The Implant Structure consists of a structural member that is combined with a frame and foundation that are embedded into the ground where they are securely supported by the ground.

The structure carries horizontal and vertical loads, using the "size of the structural member" and the "embedded depth into ground". As a result, it exhibits high strength as an aggregate, having individual structural members that are supported by the ground.

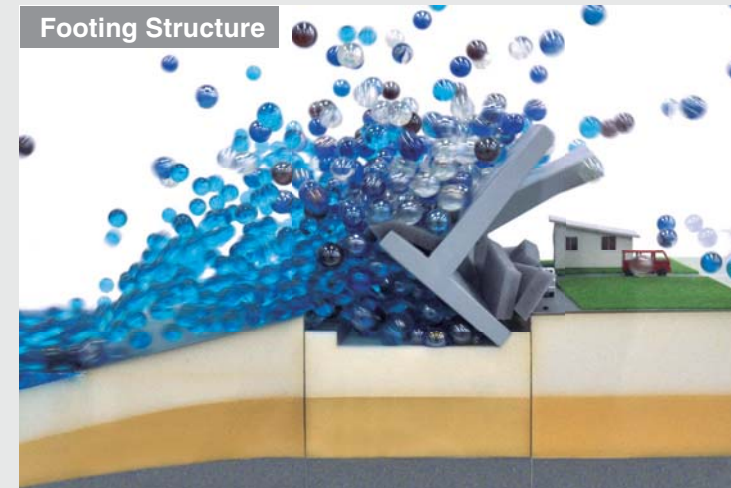
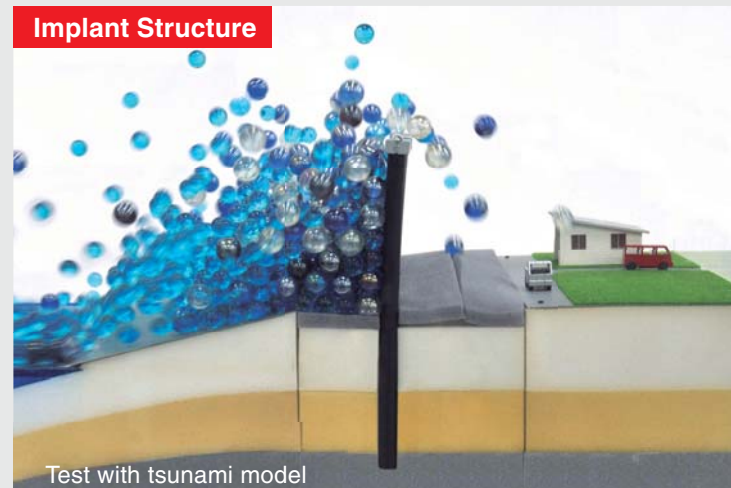
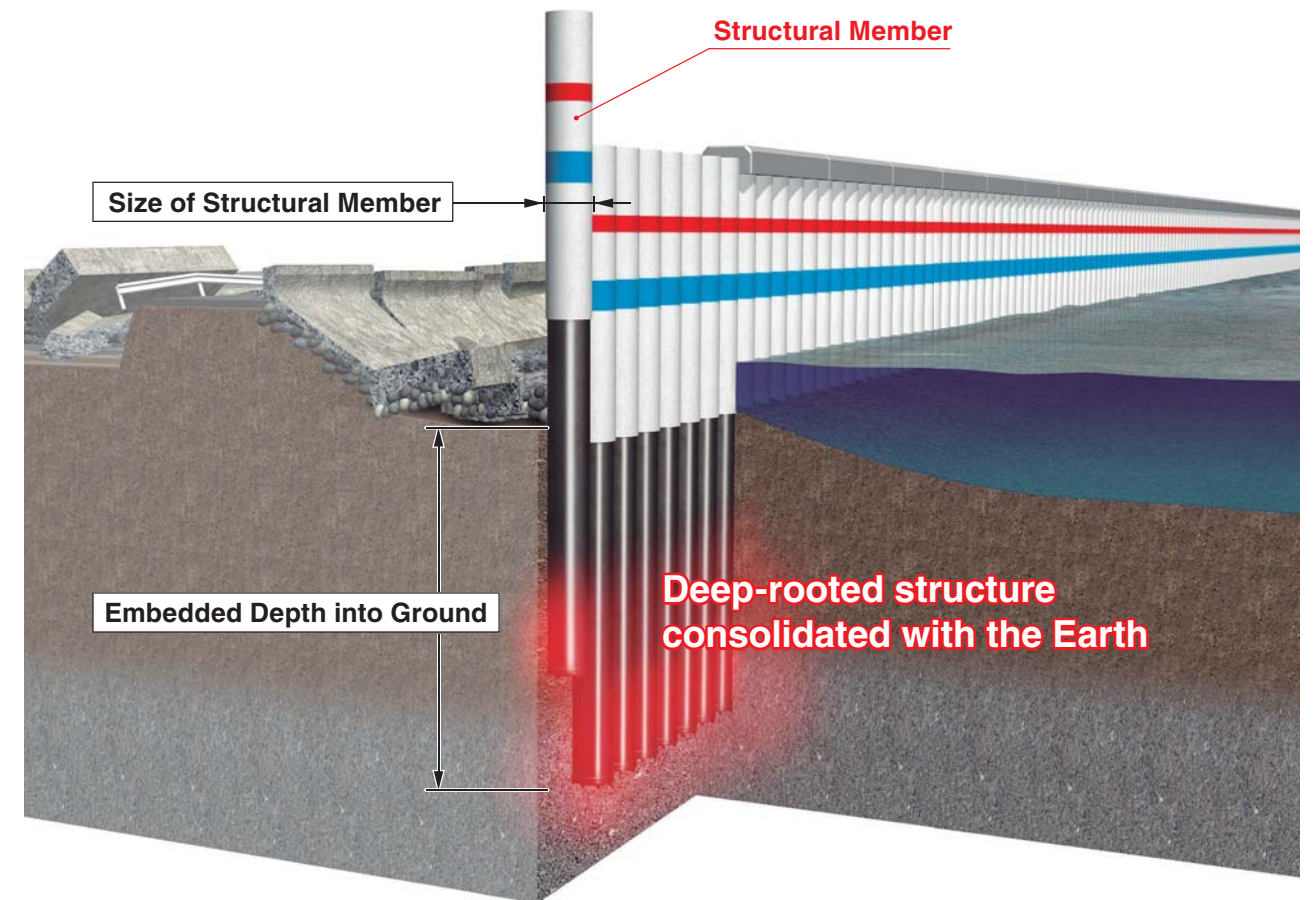

Culture Above-ground & Function Underground

Creating unique underground space with harmony of aesthetics and function

Both ECO Park and ECO Cycle are built in a cylindrical underground space, using the best of press-in technology.

Only a small entrance booth is fixed above ground, therefore, an environmentally considerate design and efficient parking are met at the same time.

The outer shaft is a cylindrical Implant Structure, which well withstands seismic external loading. This income generating facility can also double as a foundation for superstructure.

Installing function under-ground, thereby utilizing aboveground for public amenities.

Giken's underground facilities, based on the Implant Structure, contribute to society friendly and environmentally considerate aesthetic urban alternatives.

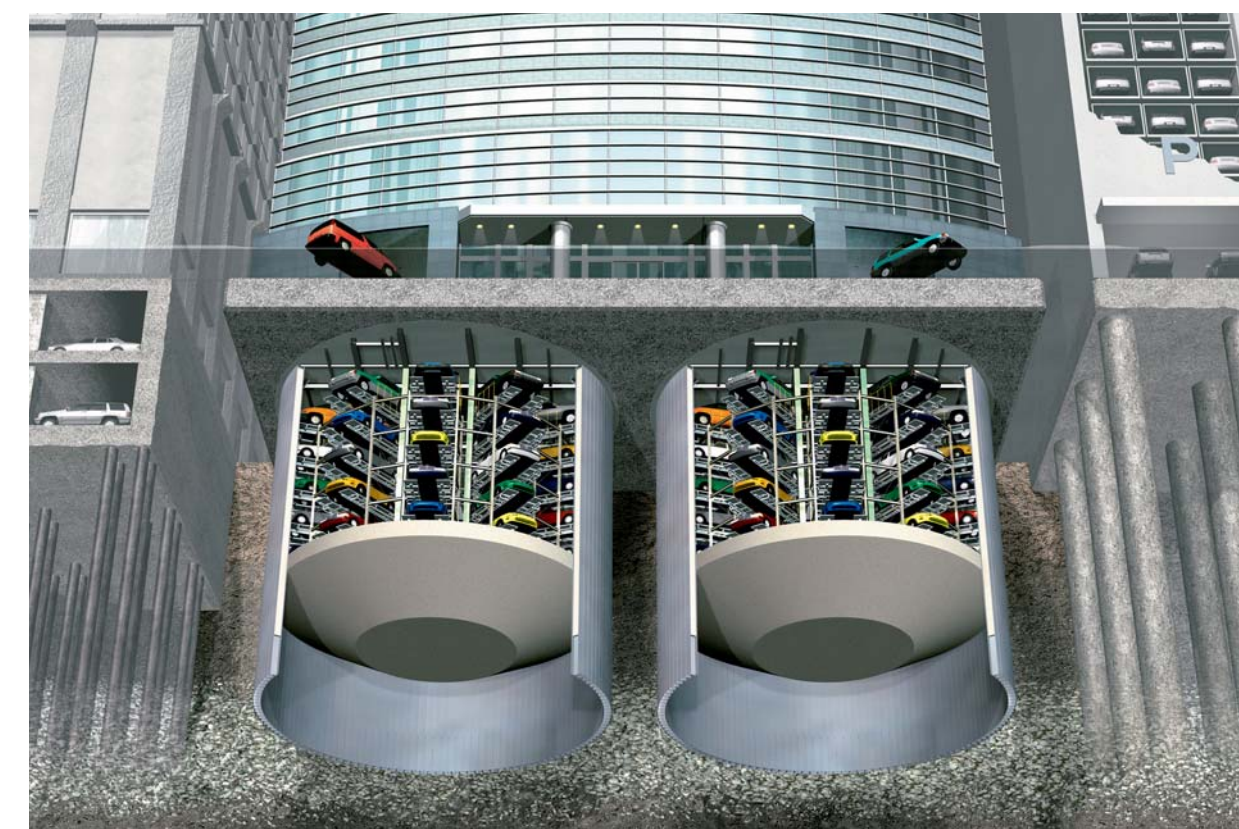

Anti-seismic Underground Bicycle Parking **ECO Cycle**

Anti-seismic Underground Car Parking **ECO Park**

Office building with an anti-seismic foundation that "generates income"

Changing Industry's Direction from "Permanent Structure" to sustainable "Functional Structure"

Promoting Implant Structure-related Technologies Worldwide as a Total Package Solution with "Minimum Temporary Work" Concept

As "IEMOTO" i.e. the head of Press-in Technology, Giken group evaluates lifecycles of the Implant Structures, through design, planning, construction, maintenance and demolition to meet the purpose of projects.

Without being restricted to precedent common practices and standards, Giken globally promotes a new construction standard i.e. "Functional Structure", which is designed based on "Minimum Temporary Work" Implant Structure. The Functional Structure serves necessary functions to cover required design life.



Implant Hat Bridge

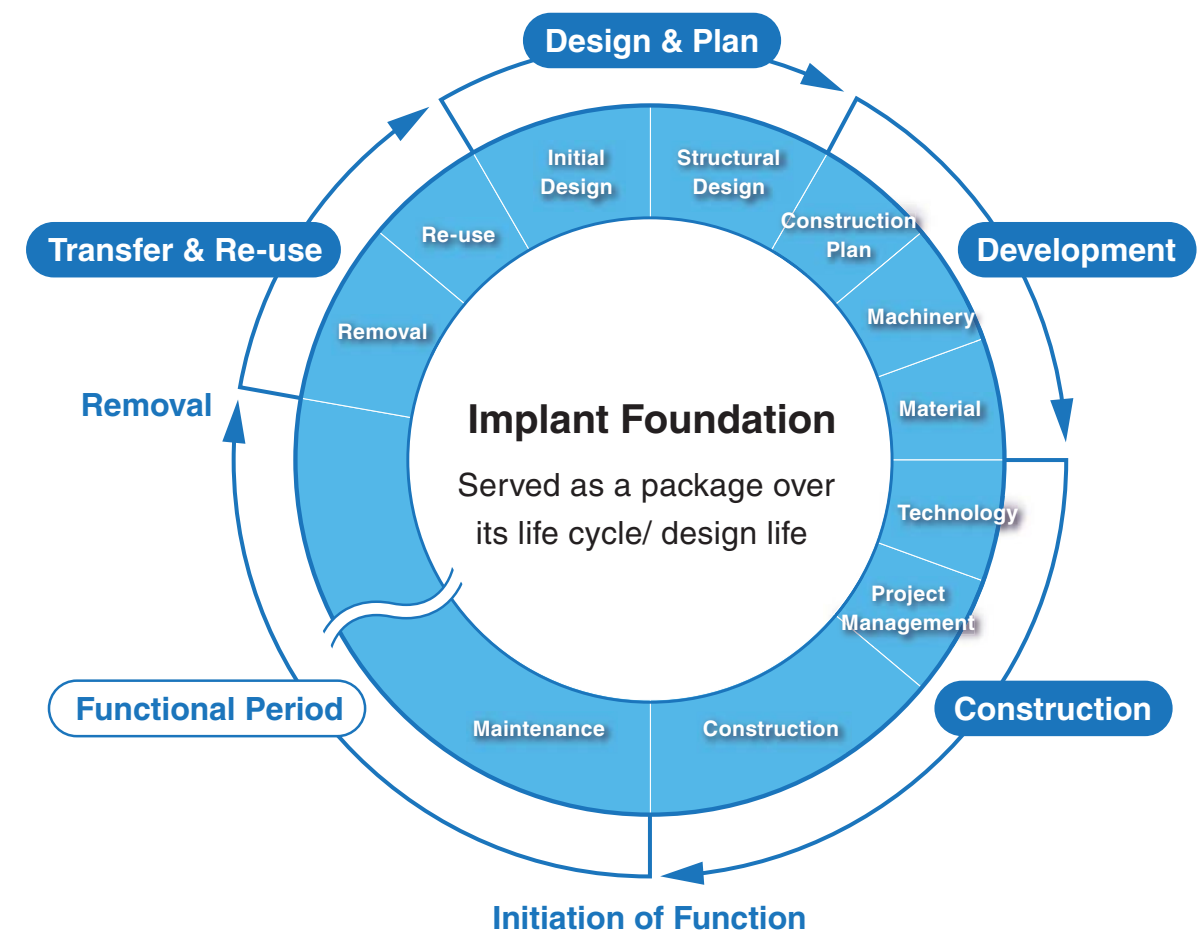
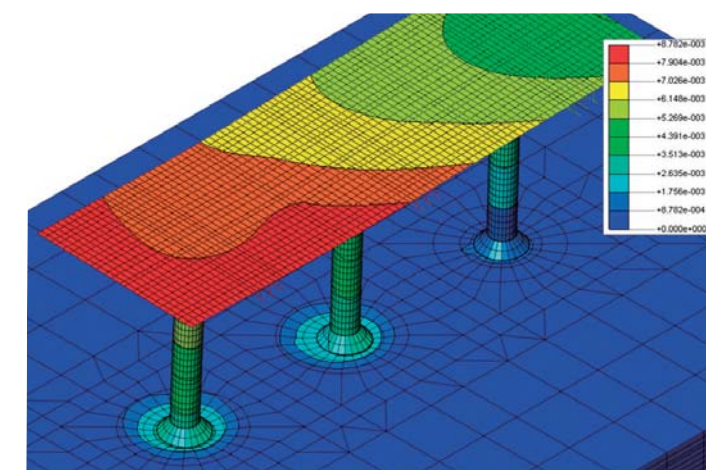
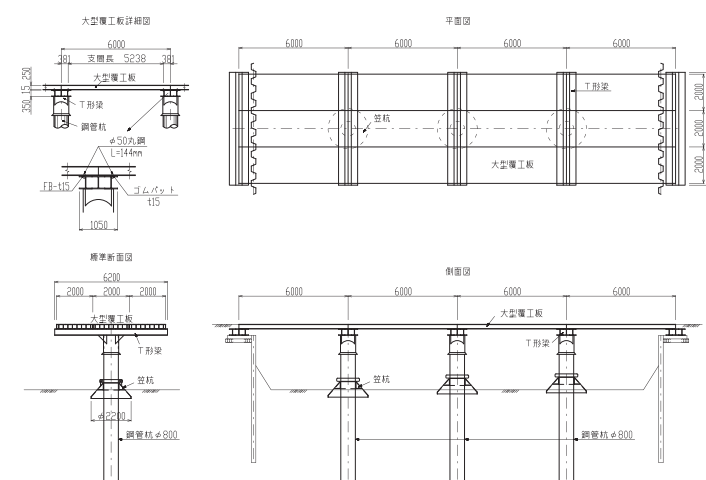

Visualizing the Advantages of the Press-in Method by Scientific Research

Verifying Structures and Methods Scientifically for Worldwide Acceptance

The real-time information of piling operation can be monitored and recorded to observe and review the operation.

Based on the monitoring data (Pile Penetration Testing), Giken Group has a system for automated operation to optimize the piling operation and bearing capacity verification technology. Currently, Giken is developing a structure sympathetic nervous system for substructure information modeling.

Also, in order to validate theory and full-scale testing, Giken started the collaborative research with the University of Cambridge, UK.

In addition, Giken was involved in the establishment of the IPA (International Press-in Association) in 2007 and is supporting their research in "Press-in Engineering", to visualize the interaction of piles with surrounding soils.

Only universal standards backed by science can be a driving force of the "Construction Revolution".

Model Testing against Tsunamis comparing Implant Structure and Gravity Foundation

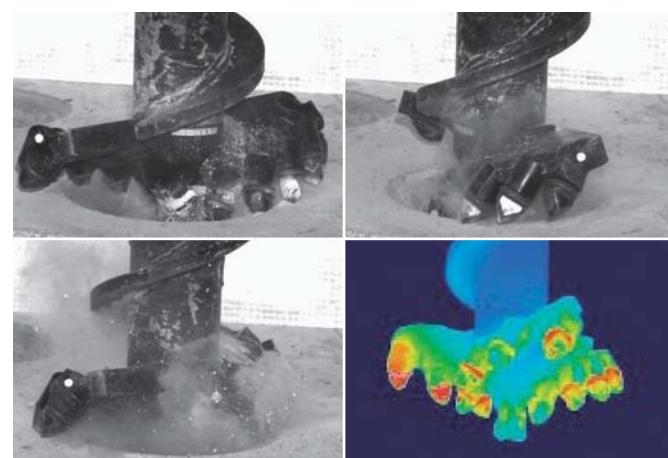
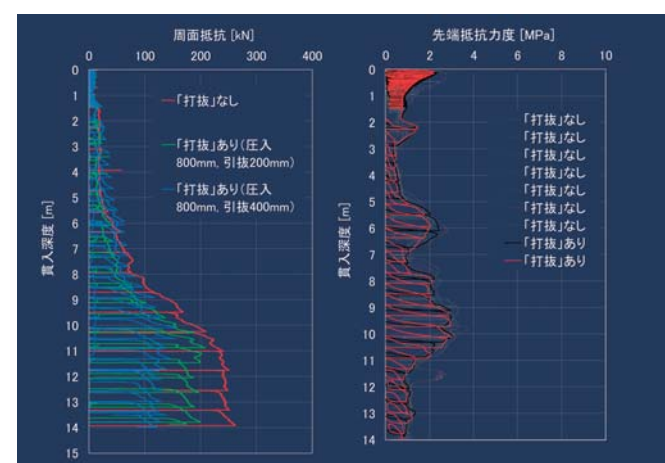
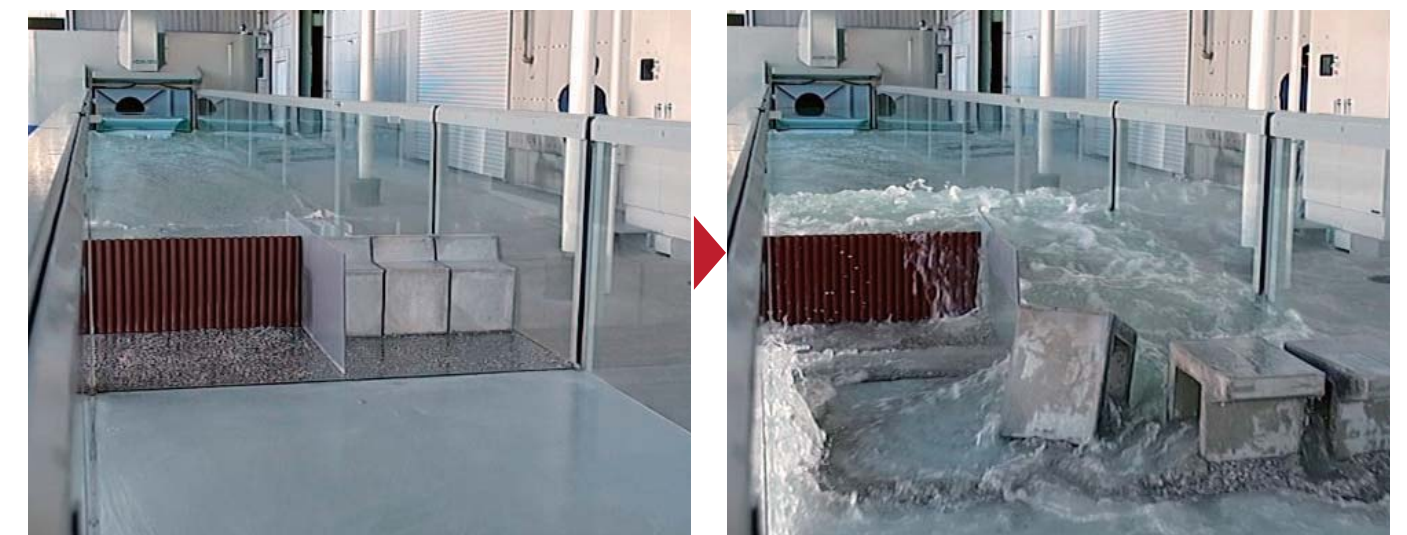



The Implant Method revolutionizing the Global Construction Industry

Coexistence of Environment and Civilization

Realizing Ideal Situations in Construction

Construction Revolution

www.giken.com

Giken Group Companies

- GIKEN LTD.
- GIKEN SEKO CO., LTD.
- CITEC INC.
- GIKEN EUROPE B.V.
- GIKEN SEISAKUSHO ASIA PTE., LTD.
- GIKEN AMERICA CORPORATION
- J STEEL GROUP PTY LIMITED



